

## MUSTANG

INDOOR LIGHTING  
ILLUMINAZIONE PER INTERNI  
WALL LAMP  
LAMPADA DA PARETE

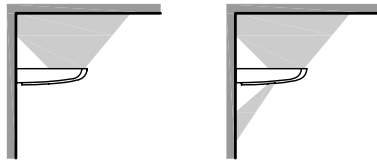
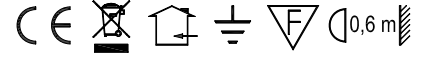

Product codes: **20200**  
RX7s 230V HQI 1x70W NDL

Product codes: **20202**  
RX7s 230V HQI 1x70W NDL

Product codes: **20201**  
RX7s 230V HQI 1x150

Product codes: **20203**  
RX7s 230V HQI 1x150

Product codes **20205**  
G24q-4 230V 2x42W

Product codes **20206**  
G24q-4 230V 2x42W

### INSTALLATION INSTRUCTIONS ISTRUZIONI DI MONTAGGIO

**WARNING!** Carefully observe the indications shown in the pictures. Any damaged components shall be replaced with similar ones. Only indoor installation. **TURN THE POWER OFF DURING INSTALLATION OR MAINTENANCE.** Altatensione shall not be responsible for any product damage caused by mounting procedures which are not in accordance with instructions.

**ATTENZIONE!** Seguire attentamente le indicazioni riportate nei disegni. I componenti che dovessero danneggiarsi devono essere sostituiti con componenti analoghi. Idoneo per il funzionamento in interni. **IN CASO DI MANUTENZIONE TOGLIERE TENSIONE.** Altatensione declina ogni responsabilità per i danni causati da un proprio prodotto montato in modo non conforme alle istruzioni.

- A. WALL PLATE / PIASTRA A PARETE
- B/D. SCREWS FOR VERTICAL REGULATION / VITI PER LA REGOLAZIONE VERTICALE
- C. SAFETY SCREW / VITE DI SICUREZZA
- E. DIE-CAST BODY / CORPO LAMPADA IN PRESSOFUSIONE
- F. CONNECTION BOX / MORSETTIERA
- G. LAMP HOLDER / PORTALAMPADA
- H. LAMP / LAMPADA
- I. SAFETY GLASS / VETRO DI PROTEZIONE
- L. METAL COVER / COVER METALLICA

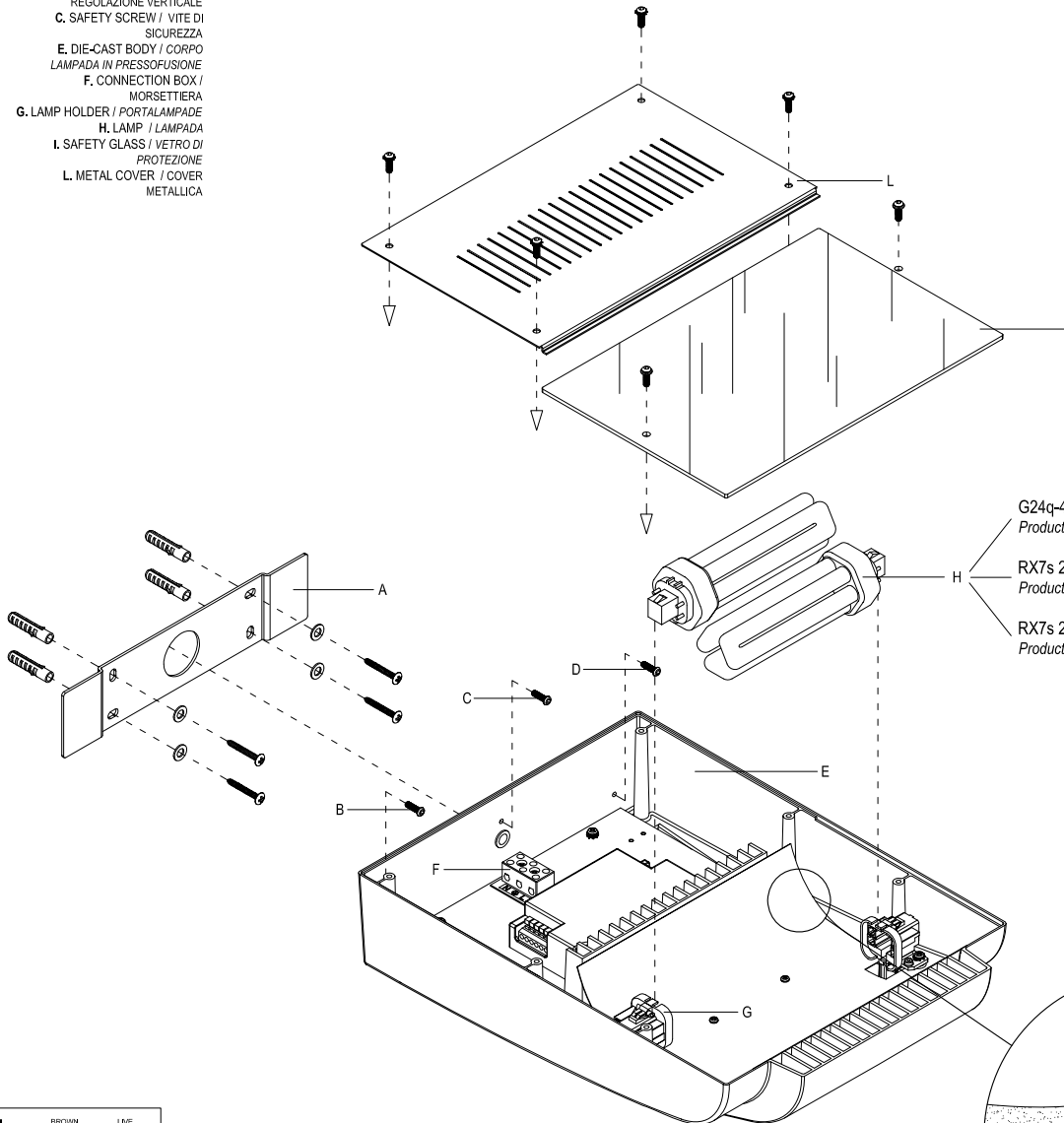

G24q-4 230V 2x42W  
Product codes 20205 / 20206

RX7s 230V HQI 1x70W NDL  
Product codes 20200 / 20202

RX7s 230V HQI 1x150W NDL  
Product codes 20201 / 20203

	L = BROWN / MARRONE	= LIVE / FASE
	N = BLUE / BLU	= NEUTRAL / NEUTRO
	= YELLOWGREEN / GIALLOVERDE	= EARTH / TERRA

**ATTENTION!** If the lamp is damaged please replace with same type and power bulb.  
**ATTENZIONE!** Se la lampada è danneggiata sostituirla con identico tipo e potenza.

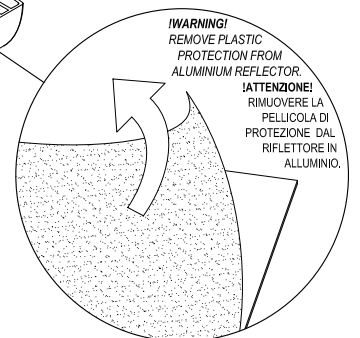

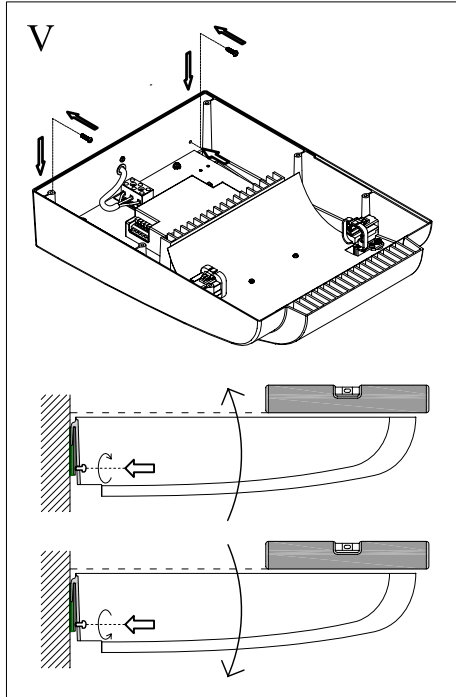
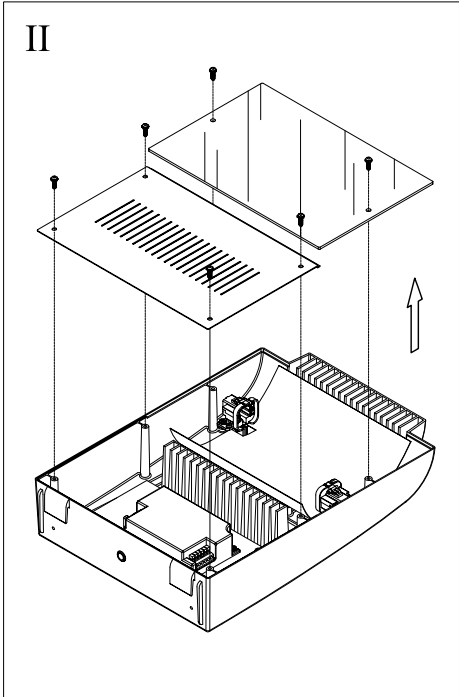
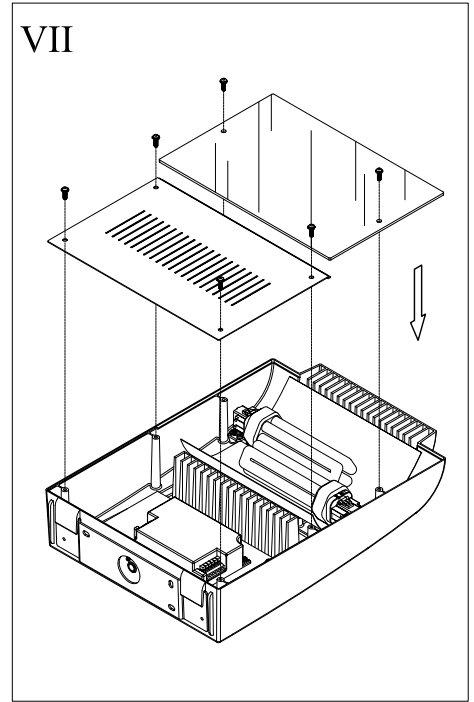
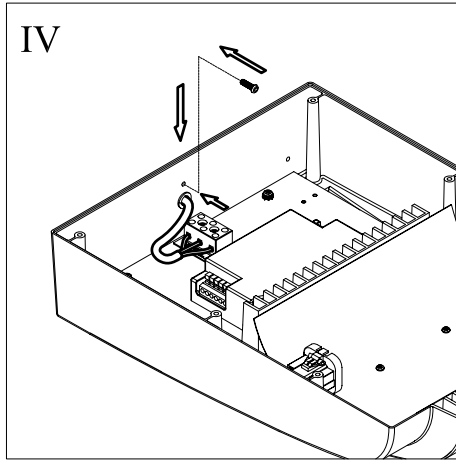
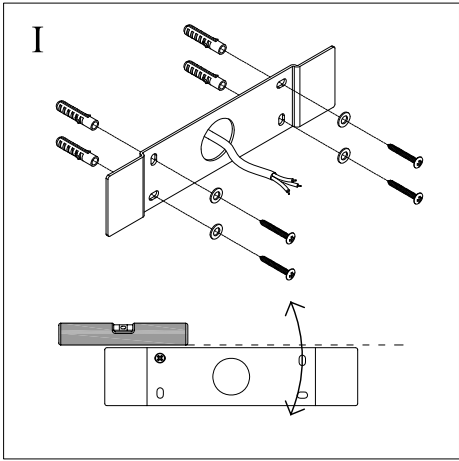

PLEASE FOLLOW NEXT STEPS FOR A CORRECT INSTALLATION:

- 1\_(**picture I**) fix the wall plate (A): adjust the plate position in order to fix it perfectly horizontal,
- 2\_(**picture II**) Open the product: first remove the safety glass (I), than the metal cover (L),
- 3\_Let the feeding cable pass through the center hole in the bottom of the die-cast body (E) and hang the product to the wall plate (A), as shown in **picture III**,
- 4\_(**picture IV**) screw (C) to fix the die-cast body (E) to the wall plate (A), then connect the feeding cables to connection box (F),
- 5\_(**picture V**) screw (B/D) in order to set the die-cast body (E) perfectly parallel to the ground. Screwing clockwise you will set the front part of the product higher, screwing anti-clockwise the opposite,
- 6\_(**picture VI**) install the lamp: HQI 1x70W for product codes 20200 / 20202, HQI 1x150W for product codes 20201 / 20203, fluorescent 2x42W for product codes 20205 / 20206,
- 7\_(**picture VII**) close the product: first fix the metal cover (L), finally the safety glass (I).

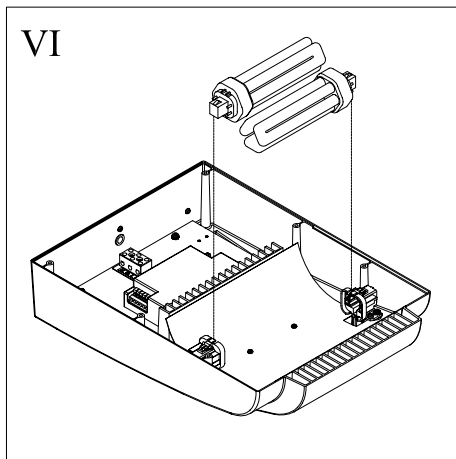
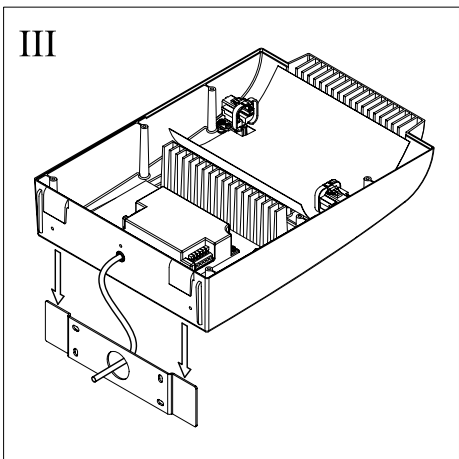

PER UNA CORRETTA INSTALLAZIONE SEGUIRE LE ISTRUZIONI:

- 1\_(**figura I**) fissare la piastra a muro (A): regolare la posizione orizzontalmente e serrare,
- 2\_(**figura II**) Aprire il prodotto: prima rimuovere il vetro di protezione (I), poi la cover metallica (L),
- 3\_Inserire il cavo di alimentazione nel corpo lampada in pressofusione (E) attraverso il foro centrale sul retro e agganciare il prodotto alla piastra a muro (A) come in **figura III**,
- 4\_(**figura IV**) avvitare (C) per ancorare (E) alla piastra a muro (A), quindi connettere il cavo di alimentazione alla morsetteria (F),
- 5\_(**figura V**) avvitare (B/D) per regolare in altezza il corpo lampada (E) e allinarlo perfettamente in orizzontale. Avvitando in senso orario il fronte del prodotto salirà, avvitando in senso antiorario il contrario,
- 6\_(**figura VI**) installare la lampada: HQI 1x70W per i codici 20200 / 20202, HQI 1x150W per i codici 20201 / 20203, fluorescente 2x42W per i codici 20205 / 20206,
- 7\_(**figura VII**) chiudere il prodotto: prima fissare la cover metallica (L), per ultimo il vetro di protezione (I).



Certification of compliance with European safety regulations LVD 73 / 23 EEC - 93 / 68 EEC.  
Certificazione di conformità alle direttive Europee di sicurezza LVD 73 / 23 EEC - 93 / 68 EEC.



You can help protect the environment! Please respect the local regulations.  
Hand-in the non-working electrical equipments to an appropriate waste disposal centre.  
Potete aiutare a proteggere l'ambiente! Ricordatevi di rispettare le normative locali.  
Consegnate le apparecchiature elettriche usate in un centro di smaltimento autorizzato.



Product suitable only for Indoor appliances. /  
Apparecchio da utilizzarsi unicamente in interni.



Safety is guaranteed by an additional conductor (earth) connected with the metal frame of body.  
La sicurezza elettrica è garantita da un conduttore supplementare (messa a terra) collegato alla struttura metallica della lampada.



Luminaires suitable for direct mounting on flammable surfaces.  
Apparecchio adatto per esser montato direttamente su superfici infiammabili.



Minimum security distance between the lth fitting and other object or surfaces (meters).  
Distanza minima di sicurezza tra l'apparecchio ed altri oggetti o superfici (metri).